

OPERATING INSTRUCTION

Brick Stack Grapple BE27

Types: BE2700, BE2701, BE2710, BE2711.



BULLITT ENGINEERING JSC

125 Bulgaria blvd., Ruse, BULGARIA

E-mail: office@bullitt-engineering.com

Contents

I. PARTS IDENTIFICATION AND STYICKERS.....	3
II. INTENDEDN USEGE.....	3
III. SAFETY USE.....	4
IV. INSTALATION.....	6
V. FUNCTIONAL CHECK.....	7
VI. TRANSPORTATION.....	7
VII. OPERATIONS.....	7
VIII. CLAMPING FORCE CHECK.....	7
IX. CLAMPING FORCE ADJUSTMENT.....	7
X. TECHNICAL DATA.....	8
XI. HYDRAULIC DYAGRAM.....	9
XII. GREASING POINTS.....	9
XIII. STORAGE, TRANSPORTAION OR SIMMILAR.....	10
XIV. FUNCTIONAL TEST AFTER EXTENDED SHUT DOWN (OVERNIGHT OR LONGER).....	12
XV. QUICK FUNCTION TEST.....	12
XVI. MAXIMUM CLAMPING FORCE REACH.....	12
XVII. COMPRESSION RAIL INSTALLATION AND REMOVAL.....	13
XIII. MAINTENANCE.....	14
XIX. TROBLESHOOTING.....	15

WARNING:

- Before starting up the operating instructions must be read and understood.
- Disregarding these operating instructions can lead to accidents and operational interruptions as well as a loss of warranty.

**I. PARTS IDENTIFICATION AND STICKERS.**

1. Hydraulic cylinder;
2. Grapple's arm;
3. Compression rail;
4. ID Plate;
5. Warning Plate;
6. Warning Plate;
7. Capacity Plate;
8. Next Inspection Plate.

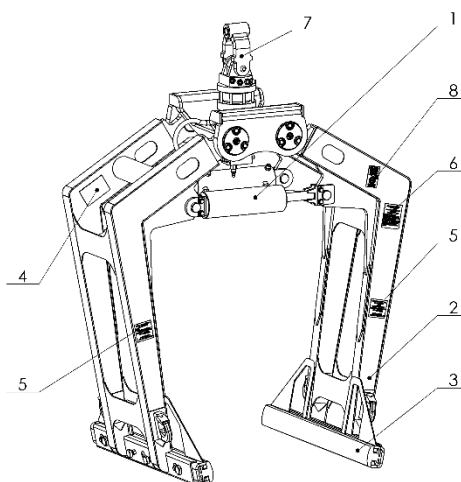
**II. INTENDED USE.**

Brick stack grapples are used for transporting brick packages on or not on pallets as well as bundled and unbundled right angle brick packages.

The BE27 grapple is intended for use on Forklift or HGV Loading Crane.

WARNING:

- The basic version of brick stack grapple may only be used close to the ground (max. lifting height = 1.8m).
- For lifting on a height greater than 1.8m , the brick stack grapple may only be used with a form-locking device in accordance with EN13155 points 5.2.7.5, 5.2.7.6 and 5.2.7.7.
- **THE LOAD MUST BE RELIEVED ONLY WHEN IT IS SET DOWN.**
- **PEOPLE WALKING UNDER THE SUSPENDED LOAD IS PROHIBITED.**



III. SAFETY USE.

The grapple clamps the package for pick up and transportation.

The friction values of the package affect directly the load capacity.

Low friction values can be caused by:

- Icy, contaminated, wet, smooth etc. package surface;
- Worn out rail rubber.

In case of the factors above, increase the friction values by:

- Replacing the worn- out rail rubbers;
- Removing contamination before picking up the load.

In case of not bundled or not palletized packages, the load capacity is additionally depended from the shape and the weight of the bricks. Special compression rails (Lamella Rails) must be used.

The rated load capacity is only valid when the package is held in correct position as described in these operating instructions.

Load capacity of the weld on hooks for load suspension is describe bellow.

The functionality of the grapple is teste

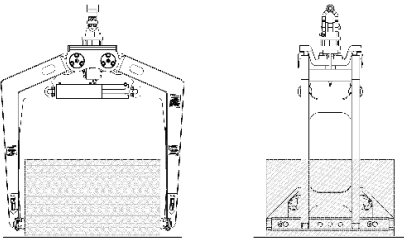
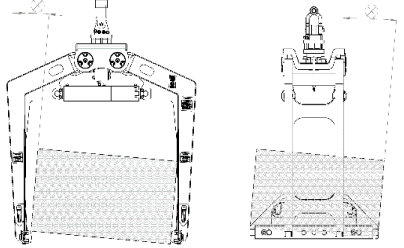
№	Description	Note
III, 1	Use only with clamped load.	
III, 2	Do not clamp the package at any angle.	

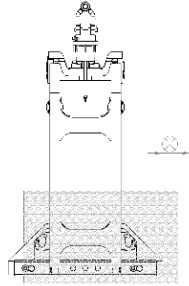
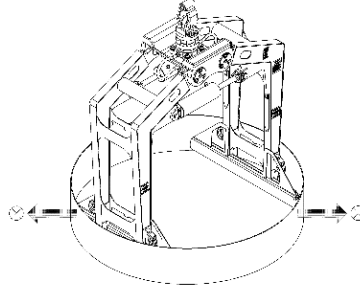
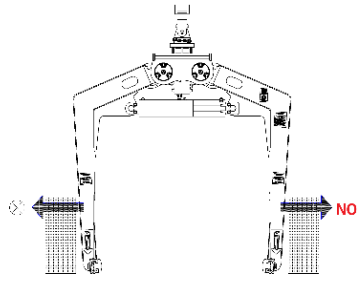
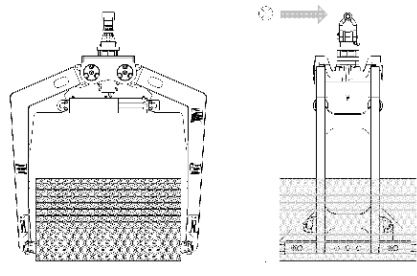
<p>III, 3</p>	<p>Do not grip and transport packages that can't be centered or that can only be clamped on one side.</p>	
<p>III, 4</p>	<p>Do not clamp oval parts by with the outside of the grab.</p>	
<p>III, 5</p>	<p>Do not open the grab against resisting surfaces.</p>	
<p>III, 6</p>	<p>Do not push horizontally.</p>	

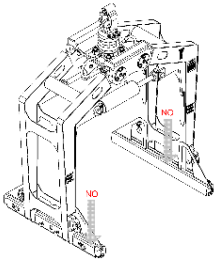
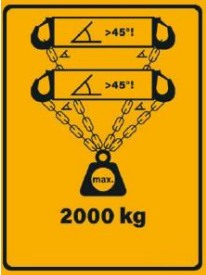
<p>III, 7</p>	<p>Do not apply vertical load on the compression rails or the gripping arm extensions. Grab the good only by means of clamping Not by reaching underneed.</p>	
<p>III, 8</p>	<p>Maximum capacity on the welded hooks is 500kg per hook. Nuber of welded lifting hooks = 4.</p>	
<p>III, 8</p>	<p>WARNING:</p> <ul style="list-style-type: none"> - Fall of the load and serious injuries may occure if the load suspending hooks are used incorrectly. - The load hooks must be used only if the package is not clamped with the attachment. The load must be distributed evenly all over the 4 welded hooks. - If the lifting attachmend is loaded and hanging at an angle, the angle of the individual slings must be greater than 45° from the horizont. - Do not exceed the maximum working load of 2000kg. 	

WARNING:

- Any use different from the specified in this document may lead to operational disturbances and loss of warranty.
- Possible loss of clamping force duo to incorrect setting down of the grapple.
- Check carrier machine operation instructions for other limitations such as wind speed, Ambient temperature and so on.



IV. INSTALATION.

The mounting of the grapple to the carrier is achieved with rotator and a link that ensures the free hanging of the grapple. If the free hanging of the grapple is prevented impermissible high forces could occur.

V. FUNCTIONAL CHECK.

- Check the permissible pressures and oil delivery rates on the carrier machined. Correct them if necessary.
- Bleed the air from the hydraulic system by opening and closing the grapple several times.
- Check the clamping force (see VII. OPERATIONS).

VI. TRANSPORTATION.

The grapple must be fastened to the vehicle securely. Follow operating instructions of the carrier.

VII. OPERATIONS.

The movement of the grapple and rotator are actuated by means of hydraulic control levers (operating levers). They are located inside the carrier machine.

Methods on the carrier machined preventing accidental actuation of the operating levers when load is suspended:

- Two hand operation,
- Automatic opening function blocking, when load is suspended.

Note: Alternative, one- hand operation is permitted in closed areas.

The grapple must be closed the full clamping force is reached when clamping package.

The movement of the control lever must be done in a controlled manner. Otherwise, control levers which springs back to neutral position automatically can lead to reduction of clamping force.

VIII. CLAMPING FORCE CHECK.

- When clamping the package hydraulic pressure must be build for a sufficient time (>2 sec).
- Observe the clamping arms deflection during the pressure build up.

If any doubt, check for causes using the troubleshooting plan and take actions accordingly.

IX. CLAMPING FORCE ADJUSTMENT.

The clamping force can be reduced in order to load sensitive goods. This is done by adjusting the pressure relieve valve located on the grapple`s hydraulic block.

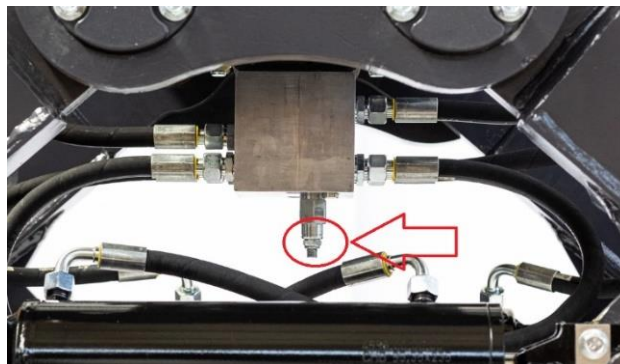

X. TECHNICAL DATA.
MODEL: BE27

Type	A, mm	B, mm	C min / max, mm	Load Capacity, kg	Own Weight, kg
BE2700	1000	1595	220 ÷ 1430	2000	392
BE2701	1100	1695	160 ÷ 1460	2000	397
BE2710	1200	1795	100 ÷ 1485	1800	402
BE2711	1300	1895	40 ÷ 1510	1600	407

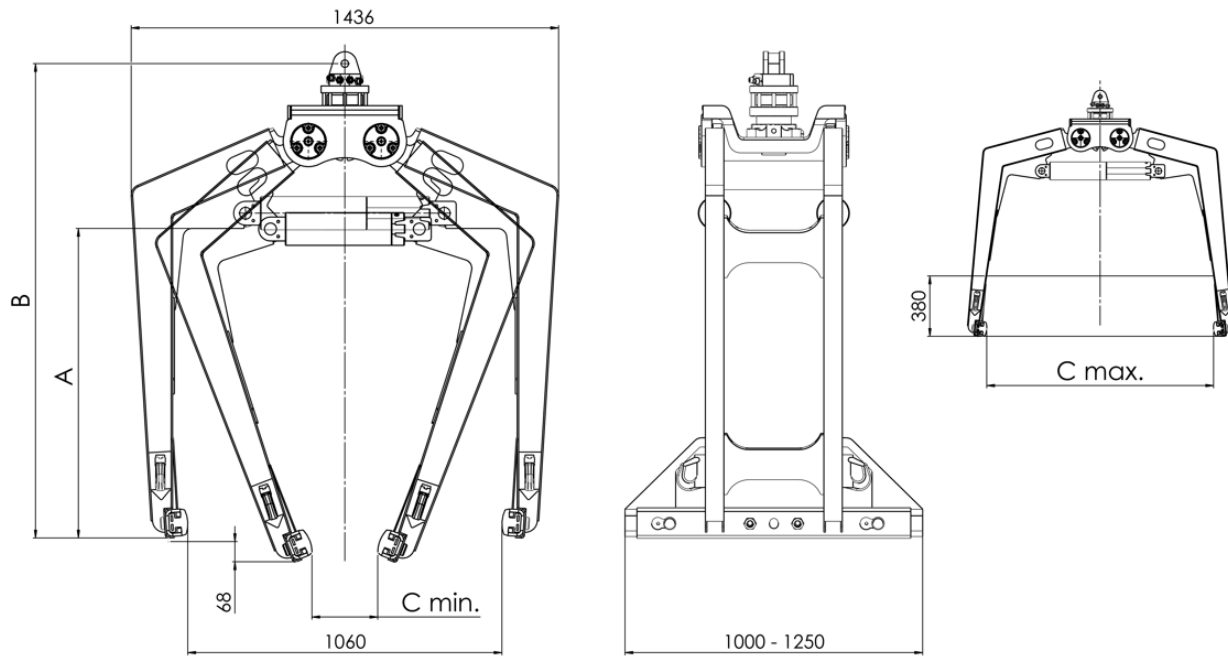

Operating pressure: 20 - 26 MPa (200 - 260 bar)

Oil Flow: max. 75 l/min

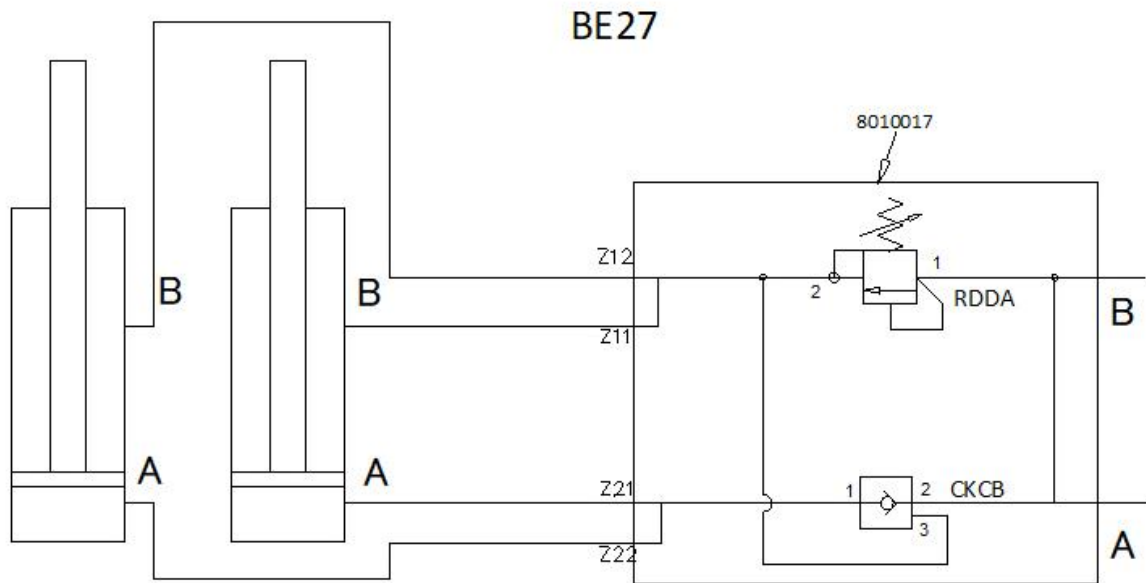
XI. HYDRAULIC DYAGRAM.

8010017- hydraulic block; RDDA-relief valve, CKCB- check valve.

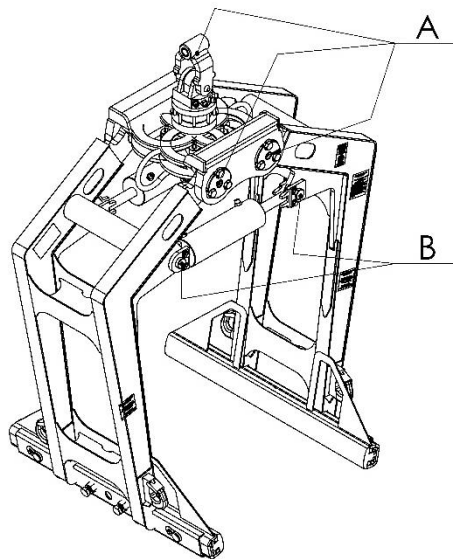
XII. GREASING POINTS.

- A- 4x Greasing Nipples,
- B- Grease the surface om both sides.

The grapple must operate with mineral hydraulic oil according the operating instructions of the carrier machine.

The equipment is functionally tested by the manufacturer. Residual hydraulic fluid MHL SAE 46 may still be present in the hydraulic system.

If the attachment is used in ecologically sensitive terrain quickly biologically degradable hydraulic fluid according to ISO 15380 or OECD301B may be used.

WARNING:

- Do not mix hydraulic fluid of different standards.
- Replace the hydraulic fluid in case of doubt for the specification of the fluid.
- Foreign hydraulic fluid presence must not exceed 2%.
- Analyse the hydraulic fluid every 500 operating hours in order to avoid premature oil changes.



Alter the accompanying operating instructions of the carrier machine.

Designed ambient temperature: -15°C ÷ 45°C.

For lubrication use multi- purpose grease **EP2 DIN51825: KP2K-20** and **ISO 6743-9: ISO L – XBCHB 2**.

XIII. STORAGE, TRANSPORTAION OR SIMMILAR.

Positions for transportation, storage and other purposes.

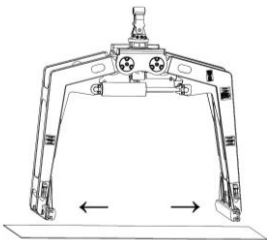
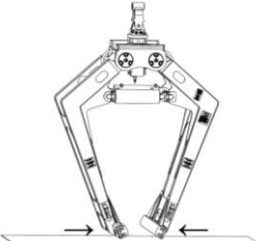
№	Description	Note
XIII, 1	Completely open	
XIII, 2	Completely closed, hydraulic cylinders must be pressurized.	

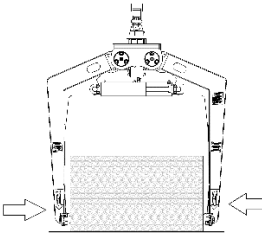
XIII, 3	Clamped on the load, hydraulic cylinders must be pressurized.	
---------	---	--

WARNING:

Hydraulic circuit malfunction may occur if the grapple is transported and stored in position different from the listed above.



Storage in free- hanging position.

Fully close and pressurize the hydraulic cylinders otherwise free- hanging may lead to malfunction and loss of clamping force.

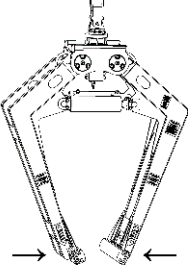
No	Description	Note
XIII, 4	Hanging position.	

Follow carrier machine operating instructions and national safety regulations.

WARNING:

Before first operation purge the air from the hydraulic system.

Possible pressure drop or loss of clamping force

due to air in the system after long shut down (over-night or other period of rest).



XIV. FUNCTIONAL TEST AFTER EXTENDED SHUT DOWN (OVER NIGHT OR LONGER).

Fully open and fully close the grapple to the end of the stroke of the hydraulic cylinders.

Hold the respective end position until the maximum pressure is reached.

Complete the full movement cycle at least two times, only then the hydraulic system is completely filled and the air is purged.

XV. QUICK FUNCTION TEST.

If storing the grapple was stored in free-hanging position but not fully closed, perform the quick function test after **XIV. FUNCTIONAL TEST AFTER EXTENDED SHUT DOWN (OVER NIGHT OR LONGER)** and **before** first use.

- Complete two full movement cycles as per **XIV. FUNCTIONAL TEST AFTER EXTENDED SHUT DOWN (OVER NIGHT OR LONGER)**. In order to ensure the air is purged from the hydraulic system and it is filled completely with hydraulic fluid.
 - Fasten zip tie to hydraulic cylinder's rod (the zip tie can remain on the rod for future tests).
 - Clamp a package until maximum pressure is reached.
 - When control lever is in neutral position, slide the zip tie until it touches seal of the piston side.
 - Wait 5 minutes. If the gap between the tie and the seal is greater than 4 mm there is still air in the hydraulic system and the grapple could not reach full clamping force.
-
- Perform **XIV. FUNCTIONAL TEST AFTER EXTENDED SHUT DOWN (OVER NIGHT OR LONGER)** again and redo **XV. QUICK FUNCTION TEST**.
 - If the gap is less than 4mm, move the zip tie in opposite position (toward rod end).
The grapple is safe to operate.

XVI. MAXIMUM CLAMPING FORCE REACH.

After the grapple is fully closed and before the load is lifted, fully pressurize the hydraulic stem by holding the control lever in close position for at least 2 second (4 seconds in case of wet material).

XVII. COMPRESSION RAIL INSTALLATION AND REMOVAL.

For easier compression rail change, rise the grapple at about 1 meter from ground. Do not stay beneath the grapple.

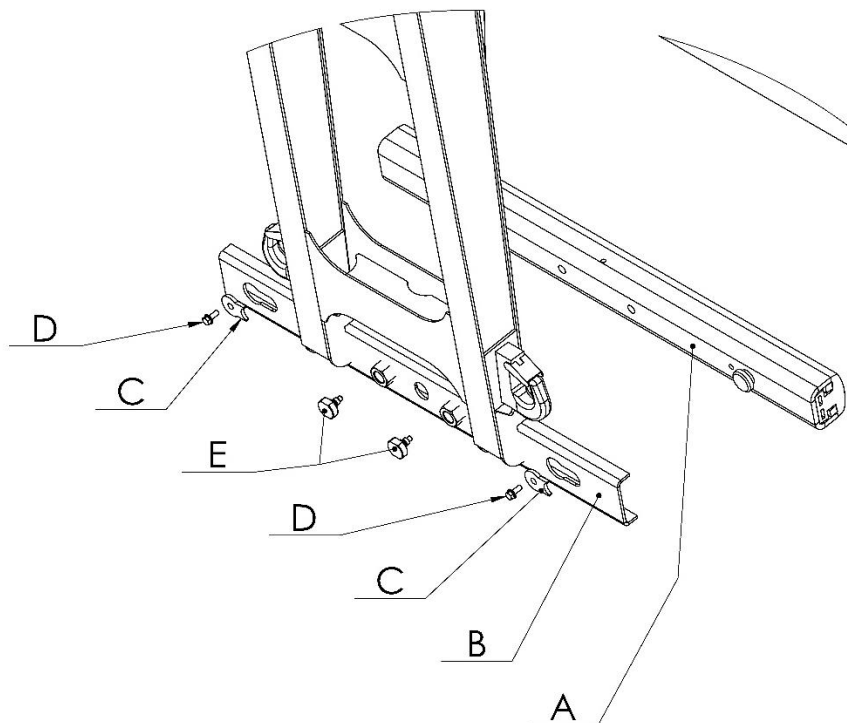

Installation:

- Fully unscrew pins **E** in order to slide compression rail **A** to the mounting profile of the grapple's arm **B**.
- Slide to the right compression rail **A** on to the mounting profile **B** until it is locked in the slots.
- Secure the compression rail with pins **E**.
- Fasten the locking inserts **C** with screws **D**.

Removal:

- Unscrew screws **D** and remove locking inserts **C**.
- Fully unscrew pins **E**.
- Slide to the left compression rail **A** on to the mounting profile of the grapple's arm **B** until it is unlocked and remove compression rail **A**.

XIII. MAINTENANCE.

Clean all hydraulic connections and surrounding prior opening the hydraulic system.

MAINTAIN	DAYLY	WEEKLY	ANNUALLY
Check for hydraulic fluid leaks. Tighten if necessary.	X		
XVI. QUICK FUNCTION TEST.	X		
Lubricate all moving parts.		X	
Check bolt connection. Tighten if necessary.		X	
Check hydraulic hoses for wear and tear. Replace of necessary.		X	
Note: Replace all hydraulic hoses every 6 year at the least.			
Check all safety part and pin joints. Tighten or replace if necessary.		X	
Check metal structure for cracks, wear, corrosion and functional safety.		X	
Perform expert inspection according the country-specific health and safety directives.			X

WARNING:

The grapple must not be used if damaged.



NOTES:

- Halve the maintenance intervals or carry them out daily if the grapple is used under intensive working conditions.

Examples of intensive working conditions: extreme level of dirt on the working side, multi- shift operations, strong external influences, frequent underwater use.

- Consult the manufacturer for filler material and welding instructions if welding work must be carried out.

XIX. TROUBLESHOOTING.

PROBLEM	PROBLEM CAUSE	CORRECTIVE ACTION
<p>Grab: does not open / grab does not close / closes gropingly. Clamping force: decreases immediately putting control lever in neutral position.</p>	Leaks from the hydraulic system	Tighten hydraulic connections or rectify other leaks. Check hydraulic couplings. Clean or replace if necessary.
	Contamination of the hydraulic system.	Fully open the grapple several times. In order to remove possible contamination, allow the oil to go through for 10 seconds.
	Leaks from hydraulic cylinder seals.	Replace the seals.
	Functional fault- return filter of carrier machine.	Clean or replace the filter if necessary.
	Functional fault-grapple`s pressure relieve valve.	Check pressure relieve valve. Clean or replace if necessary.
	Functional fault- grapple`s hydraulic block.	Check grapple`s hydraulic block. Clean or replace if necessary.

Load is slipping from compression rails.	Worn out rubber insert in the compression rails.	Replace the rubber inserts or use different kind of inserts.
	Low operating pressure on carrier machine.	Adjust pressure relieve valve (see IX. CLAMPING FORCE ADJUSTMENT)
	Lifted load greater than maximum listed in grapple`s technical data.	Reduce the load.
	Low friction values (Icy, contaminated, wet, smooth etc. package surface.	Clean the clamping area.
	Grapple`s arms joints not lubricated.	Lubricate clamping arms joints.
	Air in the hydraulic system.	Purge the air (see XIV. FUNCTIONAL TEST AFTER EXTENDED SHUT DOWN (OVER NIGHT OR LONGER).)